



The product shown may differ from standard configuration.

PRIMO® XXL

Comfort Seat with Pneumatic Suspension



PRIMO® XXL

Technical data

Comfort seat

Despite this seat's low height, its large suspension travel and low-frequency technology actively protect the user. It's also very easy to set the pneumatic suspension and extra-high backrest with mechanical lumbar support. The Primo XXL is equipped with an operator presence switch as well as a duosensitive ELR-belt system as standard.

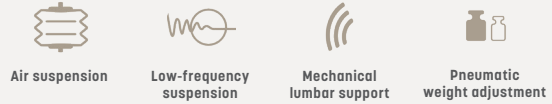

Features

ARTICLE NO.	PRIMO® XXL
Fabric, compressor 12V	1293476
STANDARD FEATURES	
Shock absorber, nonadjustable	●
Air suspension with compressor 12V	●
Low-frequency suspension	●
Suspension stroke, 50 mm	●
1 Weight adjustment, 45-170 kg, pneumatic	●
Height adjustment, 60 mm	●
2 Fore/aft adjustment, 210 mm	●
3 Lumbar support, mechanical	●

PRIMO® XXL	PRIMO® XXL
4 Adjustable backrest angle	●
5 ELR-belt system, duosensitive	●
Seat cushion width	450 mm
Operator presence switch (OPS)	●
OPTIONAL FEATURES	
6 Document box	○
7 Armrests, adjustable angle, 60 mm x 320 mm	○
Fore/aft isolator*	○
8 Seat heating	○

* Fore/aft isolator not for earth-moving machinery

Measurements (installation dimensions)

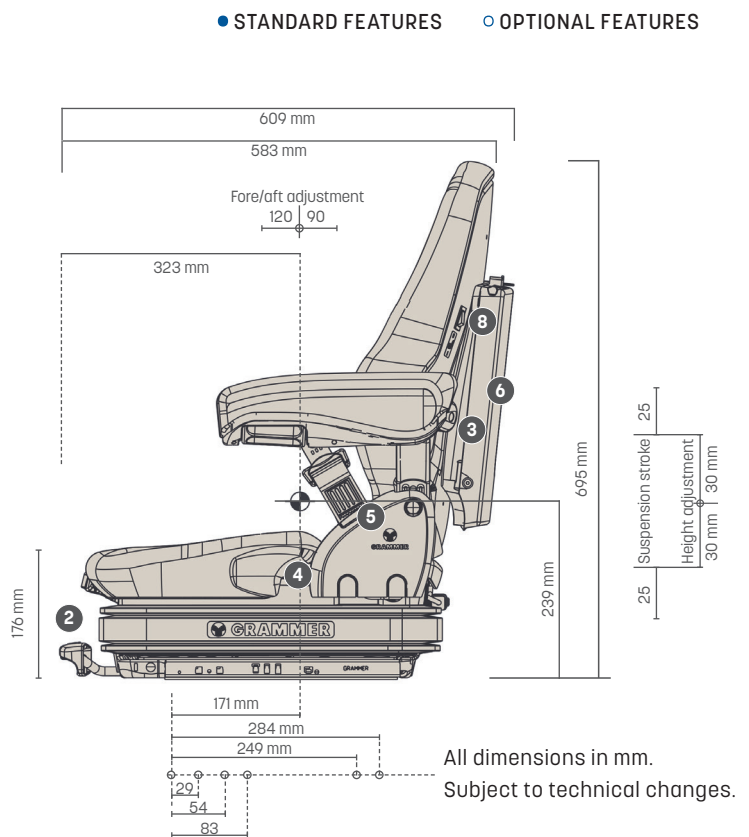
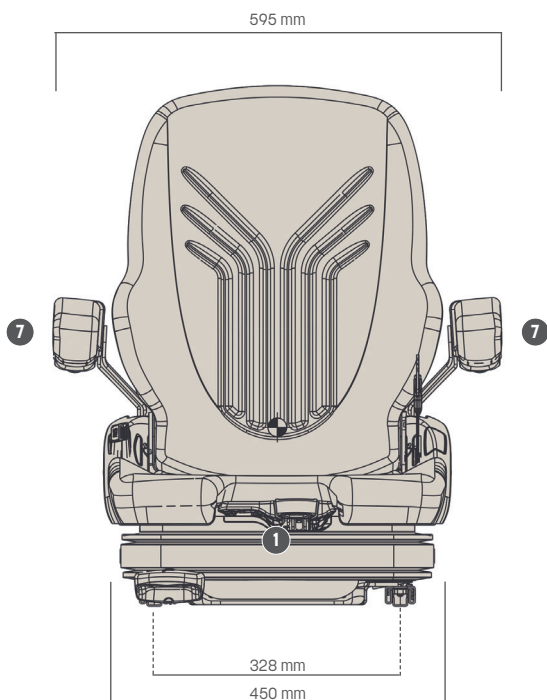

All dimensions in mm.
Subject to technical changes.