



The product shown may differ from standard configuration.

PRIMO® EL PLUS

Premium Seat with Active Weight Adjustment



PRIMO® EL PLUS

Technical data

Premium seat

The low-frequency suspension with travel of 110 mm in the Primo EL Plus delivers outstanding comfort despite the seat's low height. Its premium package of comfort-enhancing features includes passive seat climatization and active pneumatic weight adjustment, which is very advantageous with frequently changing drivers. The seat automatically sets itself to the operator's weight to maximize vibration attenuation. Integrated heating and a mechanical lumbar support are included as standard features. The seat meets the latest safety requirements and is equipped with a seat and belt contact switch as well as a duosensitive ELR-belt system with orange belt straps as standard.



Pneumatic suspension



Low-frequency suspension



Mechanical lumbar support



Passive climate system



Electronic weight adjustment

Features

Features	PRIMO® EL PLUS
ARTICLE NO.	
Fabric, compressor 12V	1492114
STANDARD FEATURES	
Shock absorber, nonadjustable	●
Pneumatic suspension with 12 V compressor	●
Low-frequency suspension	●
Suspension stroke, 70 mm	●
Weight adjustment, electronic, 45-170 kg	●
Height adjustment, 40 mm	●
Climate system, passive	●
1 Fore/aft adjustment, 210 mm	●
2 Lumbar support, mechanical	●
3 Adjustable backrest angle	●

PRIMO® EL PLUS

4 ELR-belt system, duosensitive, orange belt	●
Belt buckle with contact switch	●
Seat cushion width	520 mm
5 Seat heating	●
6 Combined seat cushion depth-angle adjustment	●
Operator presence switch (OPS)	●
OPTIONAL FEATURES	
7 Document box	○
8 Armrests, adjustable angle, 60 mm x 320 mm	○
Fore/aft isolator *	○
9 Backrest extension, integrated	○

* Fore/aft isolator not for earth-moving machinery

Measurements (installation dimensions)

● STANDARD FEATURES ○ OPTIONAL FEATURES

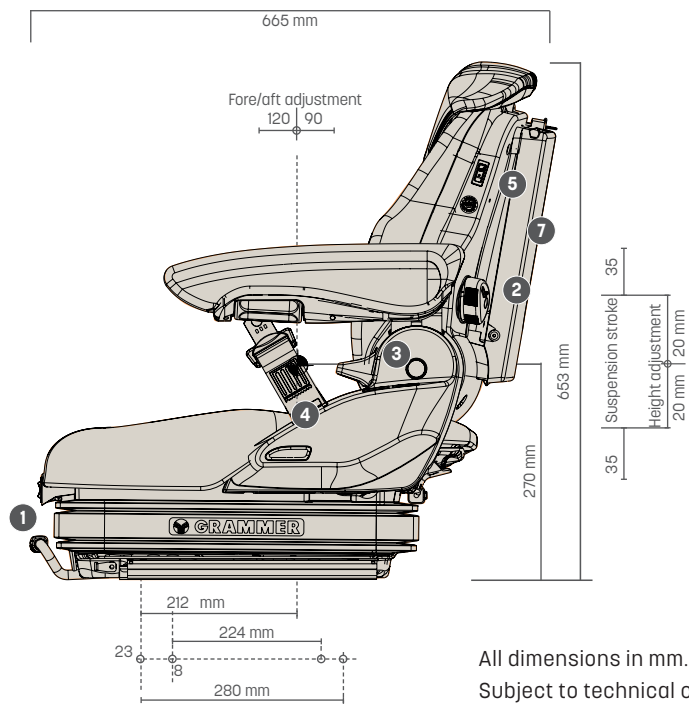
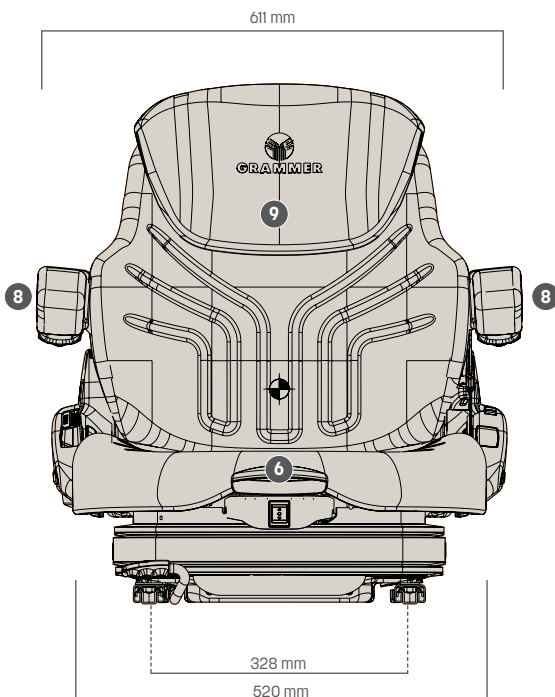

All dimensions in mm.
Subject to technical changes.