



GOOD SITTING CALLS

FOR EASY SETTING.

MSG 20

*Compact Seat for Forklifts
and Small Construction Machines.*



GRAMMER



HEALTHY POSTURE AT YOUR FINGERTIPS.



Lifting Loads is Tough on Your Body.

Your forklift may be the one doing the heavy lifting. But even so, your body is subjected to enormous unseen stresses and strains that can be extremely painful. Official statistics show that damage to bones, muscles and connective tissue accounts for most workplace injuries — and forklift operators are among those most at risk. That's why we place top priority on reducing harmful vibrations in our seats.

Take the MSG 20, for instance — it's specially designed to compensate for vibrations in forklift trucks, to give you the very best in customized comfort and safe, healthy posture.

Every Operator Has Different Suspension Needs.

It goes without saying that large men and slightly built women have entirely different suspension requirements. To cushion harmful jolts and vibrations, it's vital to maximize your seat's suspension travel.

The MSG 20 guarantees 60 mm of suspension travel to accommodate operator weights between 50 and 130 kg (110 and 286 lbs). It also features generous fore/aft and seatback angle adjustment to optimize your comfort, posture and performance.

Comfort Is Only A Click Away.

Your hectic work schedule leaves no time for elaborate experiments. And forklift trucks are often driven by several different operators. So safe, comfortable posture has to be a practicable reality, not just wishful thinking. That's why we've designed the MSG 20 to be as easy to adjust as possible:

You can adjust the seat to your weight in seconds using a straightforward lever. To customize the suspension and shock absorbers, simply click. All user controls are ergonomically positioned — so every driver can enjoy the health benefits of the MSG 20, even when the pressure's on.

1 Practical design

Ergonomically shaped seat and back cushions for optimum lateral support (also when driving backwards).

5 Seatback angle adjustment

The seatback adjusts over a range of -5° to $+5^{\circ}$ with 3 locking positions, to give your back full support for every job and make sure you feel your best.

2 Weight adjustment

Just sit down, press the smooth-action lever, click, and you're primed for action, with optimum suspension for all operator weights between 50 and 130 kg (110 and 286 lbs). Design comfort with driver appeal – it only takes one simple action to adjust the suspension to the ideal sitting position that's best for you and your back.



Illustration may deviate from series.

4 Fore/aft adjustment

The seat can be positioned over a range of 150 mm, giving you plenty of room to maneuver in every height and work situation.

3 Seatbelt system

The dual-sensitive seatbelt provides maximum freedom of movement, yet ensures that you're safely restrained in your seat, even if your vehicle should crash or tip over.

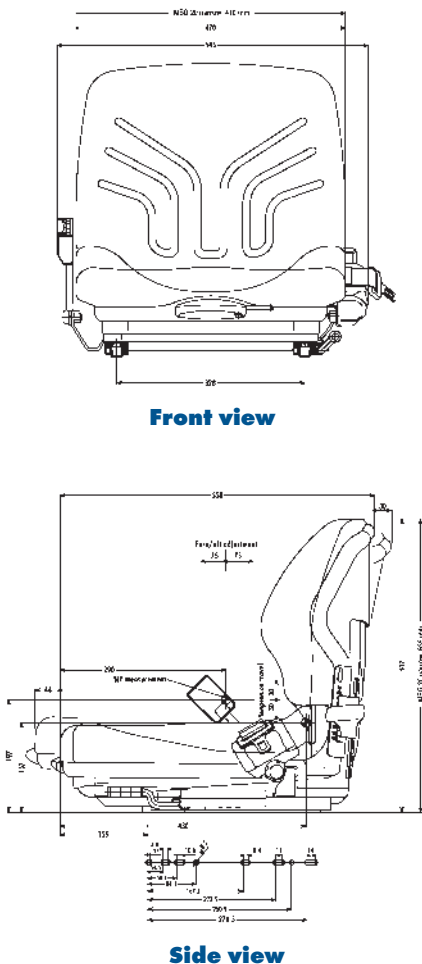

STANDARD FEATURES	MSG 20	MSG 20	MSG 20	MSG 20	MSG 20 narrow	MSG 20 narrow
Art. nos. for imitation leather	143465	143467	141999	142001	135671	135673
Art. nos. for fabric	143466		142000	142002	135672	135674
Suspension						
Mechanical suspension	●	●	●	●	●	●
Suspension travel						
60 mm	●	●	●	●	●	●
Weight adjustment						
50 - 130 kg (110 - 286 lbs) range	●	●	●	●	●	●
Fore/aft adjustment						
150 mm	●	●	●	●	●	●
Cushions						
Narrow 410 mm for reach trucks					●	●
Wide 470 mm	●	●	●	●		
Seatback angle adjustment	●	●	●	●	●	●
Seatbelt system						
Nonretracting belt			○	○		
Retracting belt			○	○		
Dual-sensitive retracting belt	●	●				
Seat switch	●			●		●
OPTIONAL FEATURES						
Folding armrests						
54 mm x 300 mm	○	○	○	○	○	○
Seat heating						
12 V, 24 V or 48 V	○	○	○	○		

● Standard ○ Optional

All measurements in diagrams are in mm. We reserve the right to make technical and dimensional changes.

**Seating systems that keep you fit:
GRAMMER offers state-of-the-art
products for all mobile work-
places - from tractors, construction
machines, and forklift trucks all
the way to trucks, buses, vans,
and trains. Ergonomically de-
signed, they set new standards
of sitting comfort and operating
convenience. Just ask us - we'll be
happy to personally advise you.**



GRAMMER AG Seating Systems • P.O. Box 14 54 • 92204 Amberg, Germany

Phone: +49 (0) 96 21/8 80-8 70 • Fax: +49 (0) 96 21/8 80-8 80 • GrammerHandel@grammer.com • www.grammer.com